

From: Scala, Mary Joy
Sent: Monday, January 28, 2013 11:26 AM
To: jtr6b@eservices.virginia.edu
Cc: 'rrodriguez@pikes.org'
Subject: BAR Action 513 Rugby Rd January 15 2013

January 28, 2013

West Range Castle Dango, LLC
8347 West Range Core
Memphis, TN 38125

Certificate of Appropriateness Application (Deferred from May 2012)

BAR 12-05-06
513 Rugby Road
Tax Map 5 Parcel 53
Jeff Riley, Applicant/ West Ranger Castle Dango, LLC, Owner
Railing Replacements

Dear Applicant,

The above referenced project was discussed before a meeting of the City of Charlottesville Board of Architectural Review (BAR) on January 15, 2013. The following action was taken:

The BAR accepted (7-0-1 with Hogg recused) applicant's request for deferral. The BAR asked to see better scaled drawings and a more clever way to attach the rails to the columns. Some BAR members asked for a wood rail with metal encased in the top rail; others said a metal rail would be appropriate.

In accordance with Charlottesville City Code 34-285(b), this decision may be appealed to the City Council in writing within ten working days of the date of the decision. Written appeals, including the grounds for an appeal, the procedure(s) or standard(s) alleged to have been violated or misapplied by the BAR, and/or any additional information, factors or opinions the applicant deems relevant to the application, should be directed to Paige Barfield, Clerk of the City Council, PO Box 911, Charlottesville, VA 22902.

Please resubmit when you are ready. If you have any questions, please contact me at 434-970-3130 or scala@charlottesville.org.

Sincerely yours,

Mary Joy Scala, AICP
Preservation and Design Planner

Mary Joy Scala, AICP
Preservation and Design Planner
City of Charlottesville
Department of Neighborhood Development Services
City Hall - 610 East Market Street
P.O. Box 911
Charlottesville, VA 22902
Ph 434.970.3130 FAX 434.970.3359
scala@charlottesville.org

513 Rugby Road



STREET ADDRESS:	513 Rugby Road
MAP & PARCEL:	5-53
PRESENT ZONING:	R-3
ORIGINAL OWNER:	
ORIGINAL USE:	Fraternity House
PRESENT USE:	Fraternity House
PRESENT OWNER:	White Horse Holding Co.
ADDRESS:	Downer Realty P.O. 17 Charlottesville, Va. 22902
DATE/ PERIOD:	Ca. 1913
STYLE:	Georgian Revival
HEIGHT IN STORIES:	2.5 stories
DIMENSIONS AND LAND AREA:	6,062 sq ft/0.228 acres
SOURCES:	Charlottesville City Records and 2004 Architectural Survey
CONTRIBUTING:	Yes

ARCHITECTURAL DESCRIPTION

This large, 2 ½-story, Georgian Revival-style, brick dwelling was constructed ca. 1913 for the local chapter of Pi Kappa Alpha national fraternity, which was founded at UVA in 1868. Details include: a gable roof with 3 pediment front dormers; 2 large interior-end brick chimneys; a symmetrical 5-bay front; 1-story, 2-bay porches at each end; brick belt course; bold wooden modillion cornice; front entry shelter with Tuscan columns and pilasters. This handsome Neo-Georgian dwelling was built around 1913 and is a contributing resource in the District.

Vann's Welding & Ornamental Works, inc.

709 Sikes Mill Road • Monroe, N.C. 28110

Phone: 704-289-6056 • Fax: 296-0411

Mobile: 704-622-7300 • Nextel: 21*37300

12-14-12

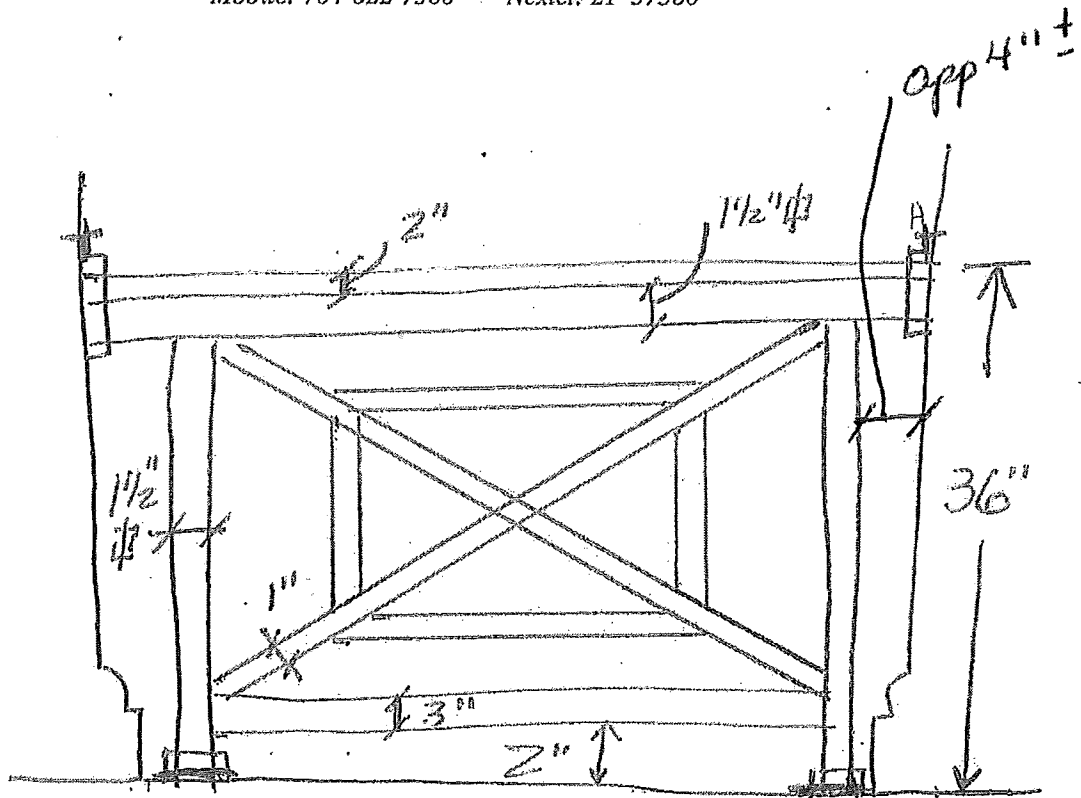

NOT TO SCALE

This will
NOT MEET
4" Φ Building
Code But will
PASS under Historic
AS WAS:

