

SECOND STREET PARTIAL ELEVATION

1/4" = 1'

A1
1

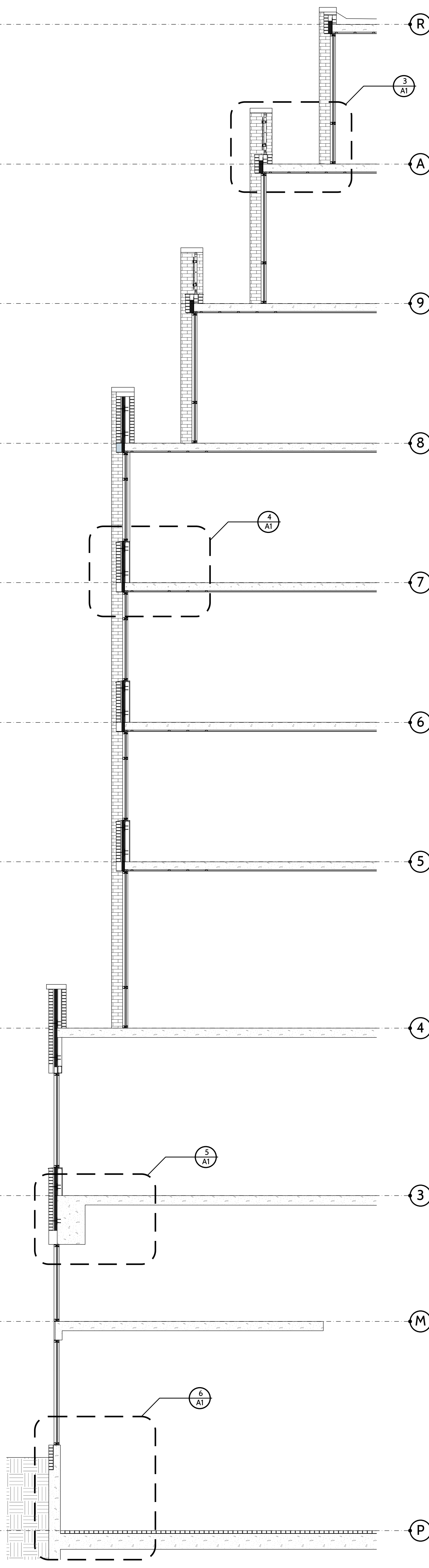

SECOND STREET PUNCHED OPENING SECTION

1/4" = 1'

A1
2

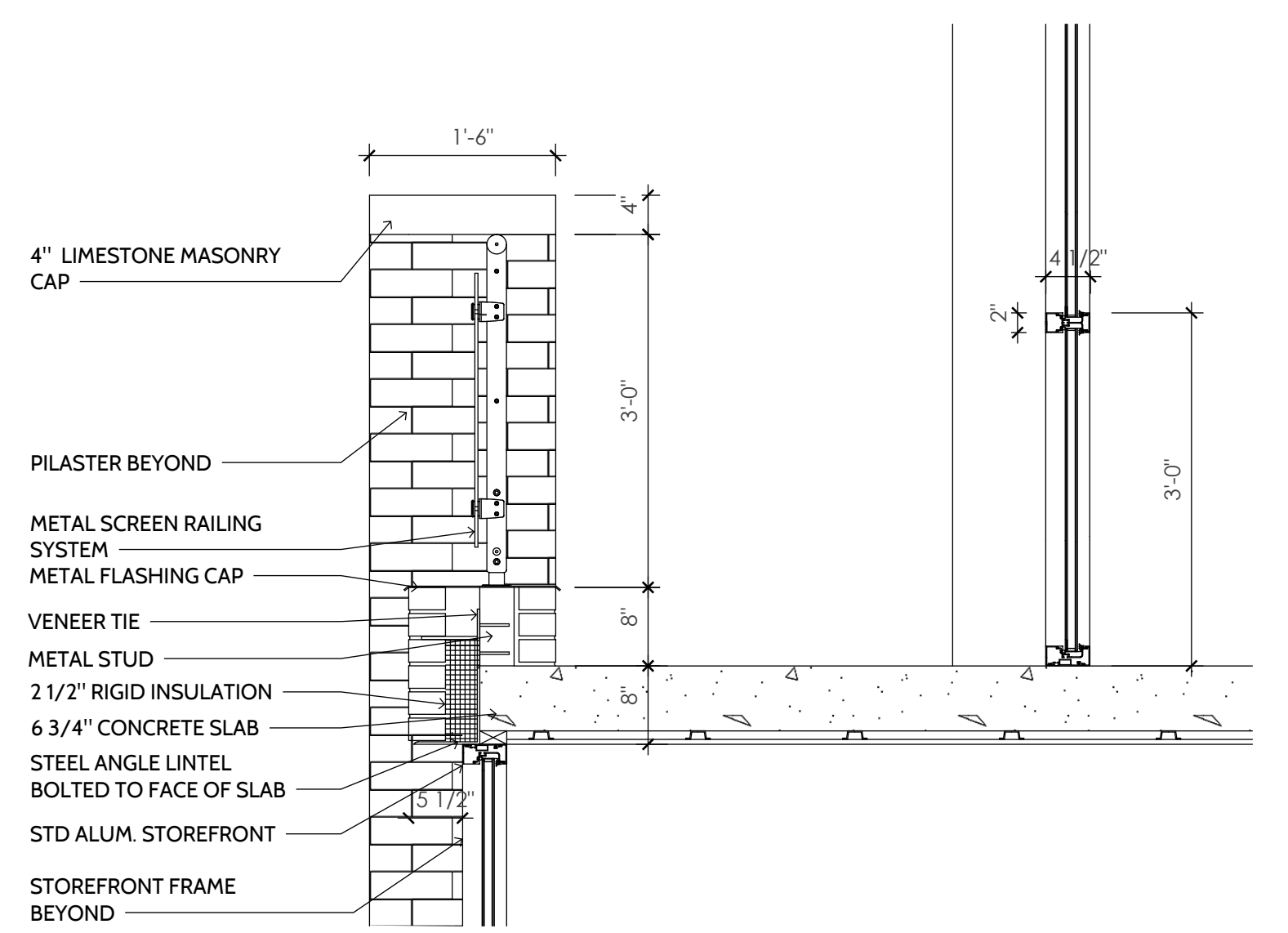

TYPICAL BALCONY RAILING

3/4" = 1'

A.1
3

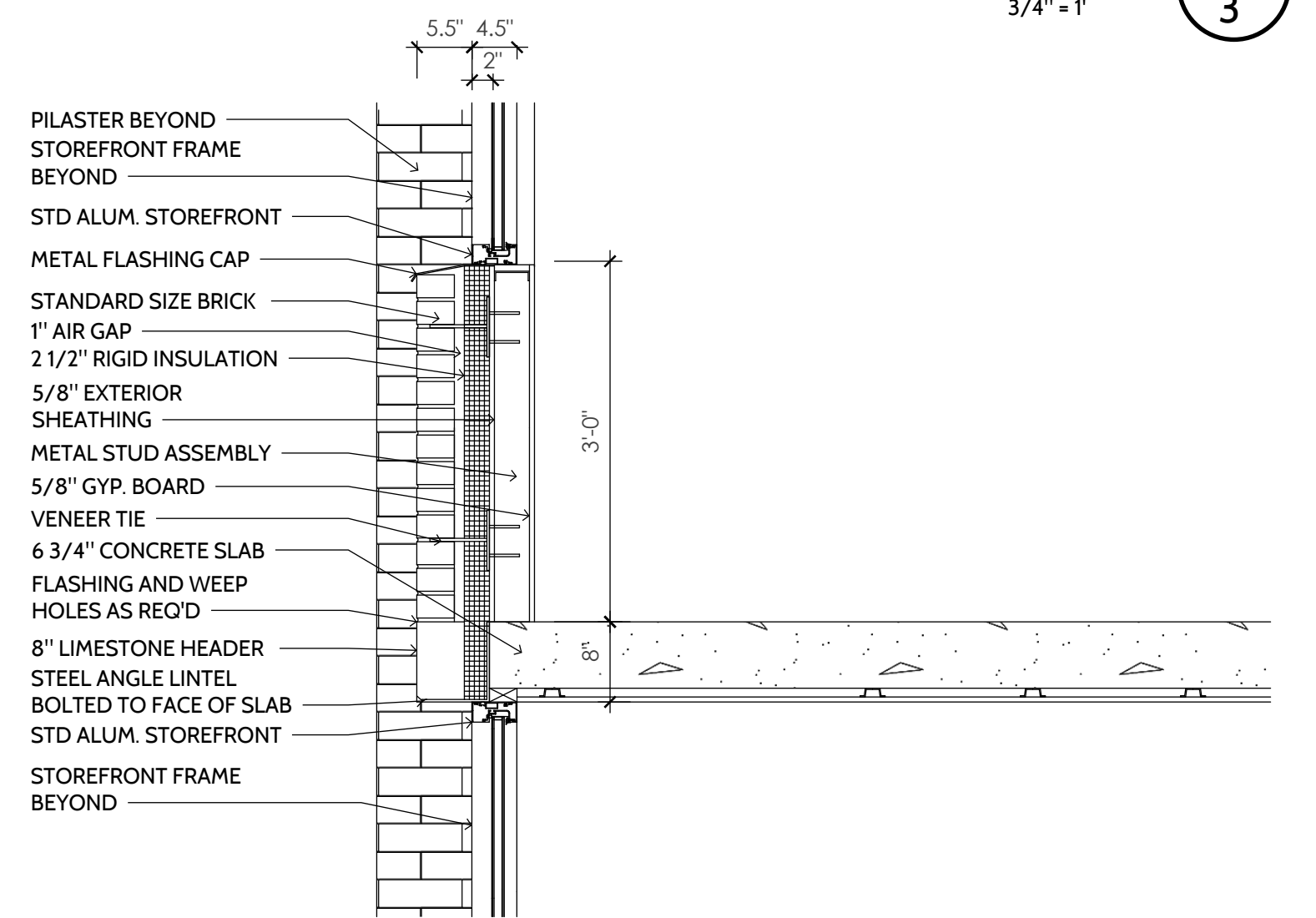

TYPICAL PUNCHED OPENING SILL AND HEADER

3/4" = 1'

A.1
4

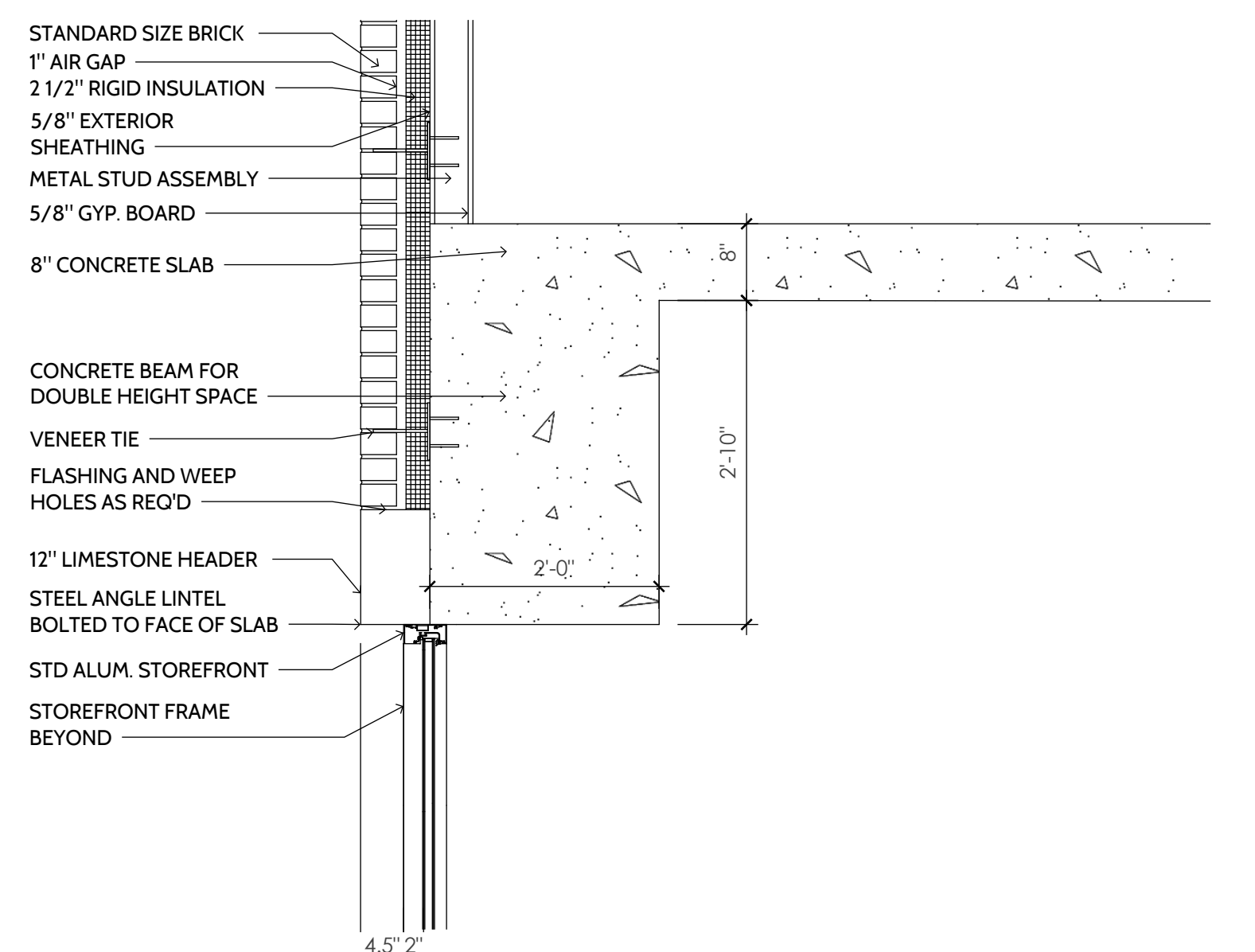

TRANSFER BEAM AND HEADER AT MEZZANINE

3/4" = 1'

A.1
5

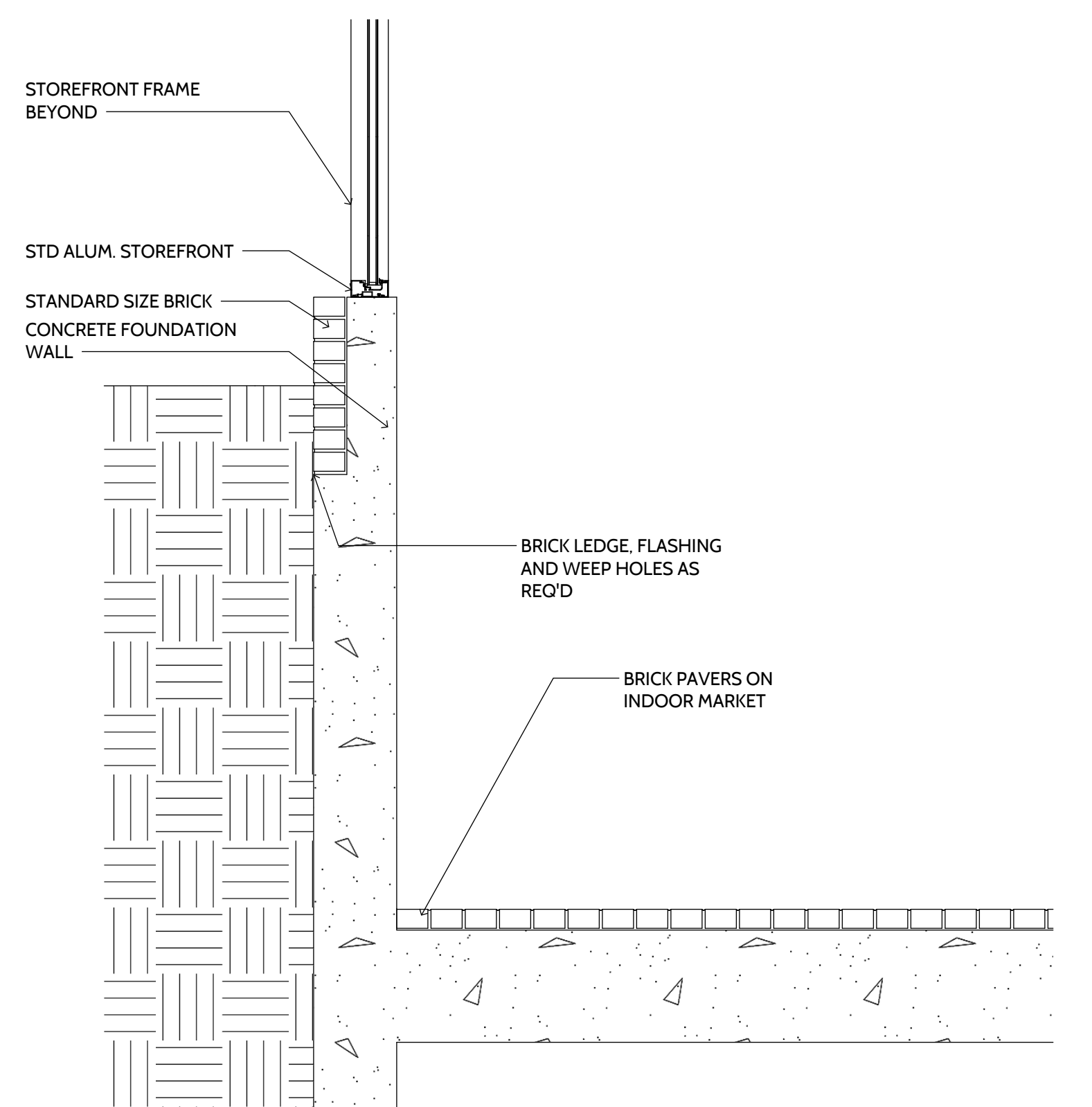

BELOW GRADE MARKET FOUNDATION WALL

3/4" = 1'

A.1
6

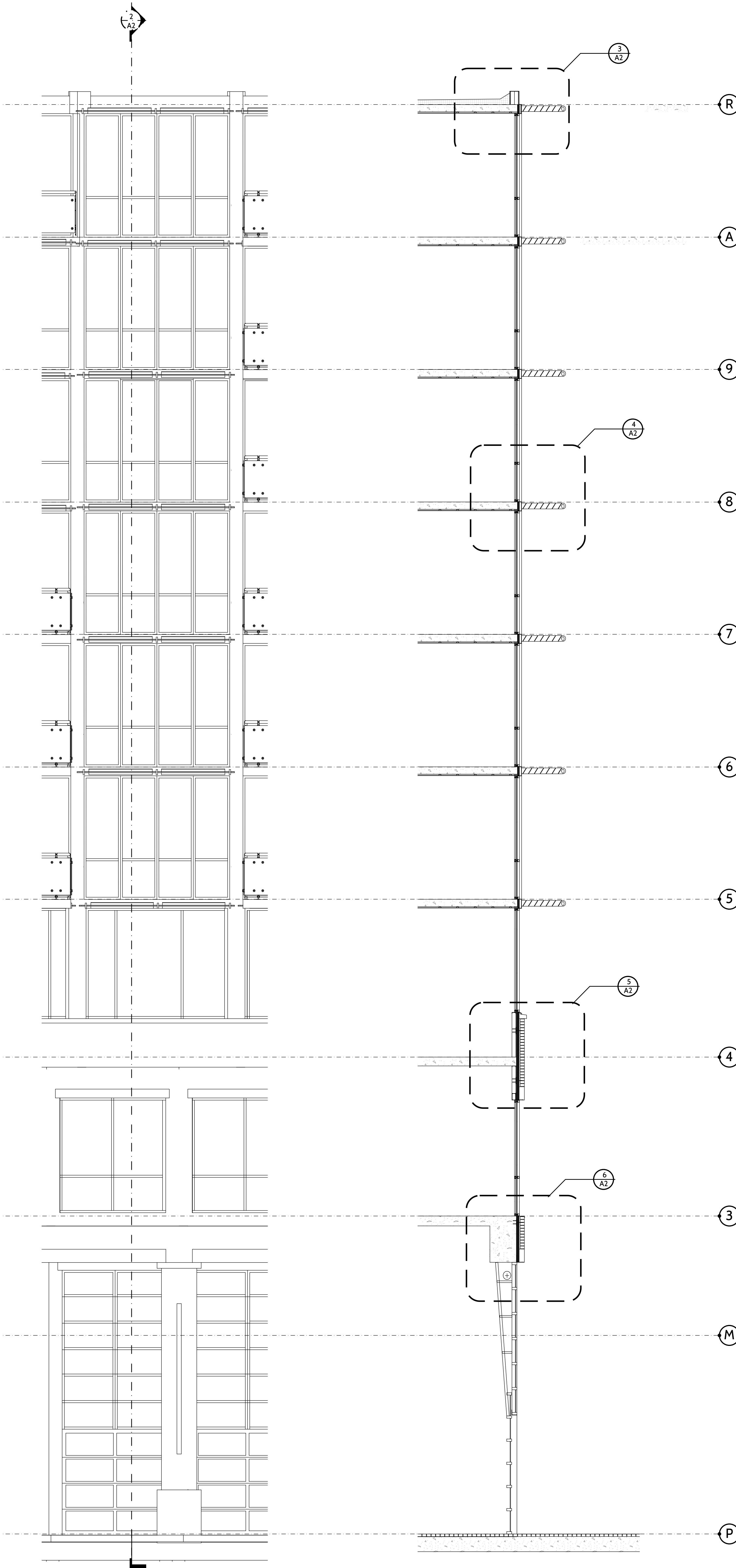

FIRST STREET PARTIAL ELEVATION

1/4" = 1'
A2
1

FIRST STREET CURTAIN WALL SECTION

1/4" = 1'
A2
2

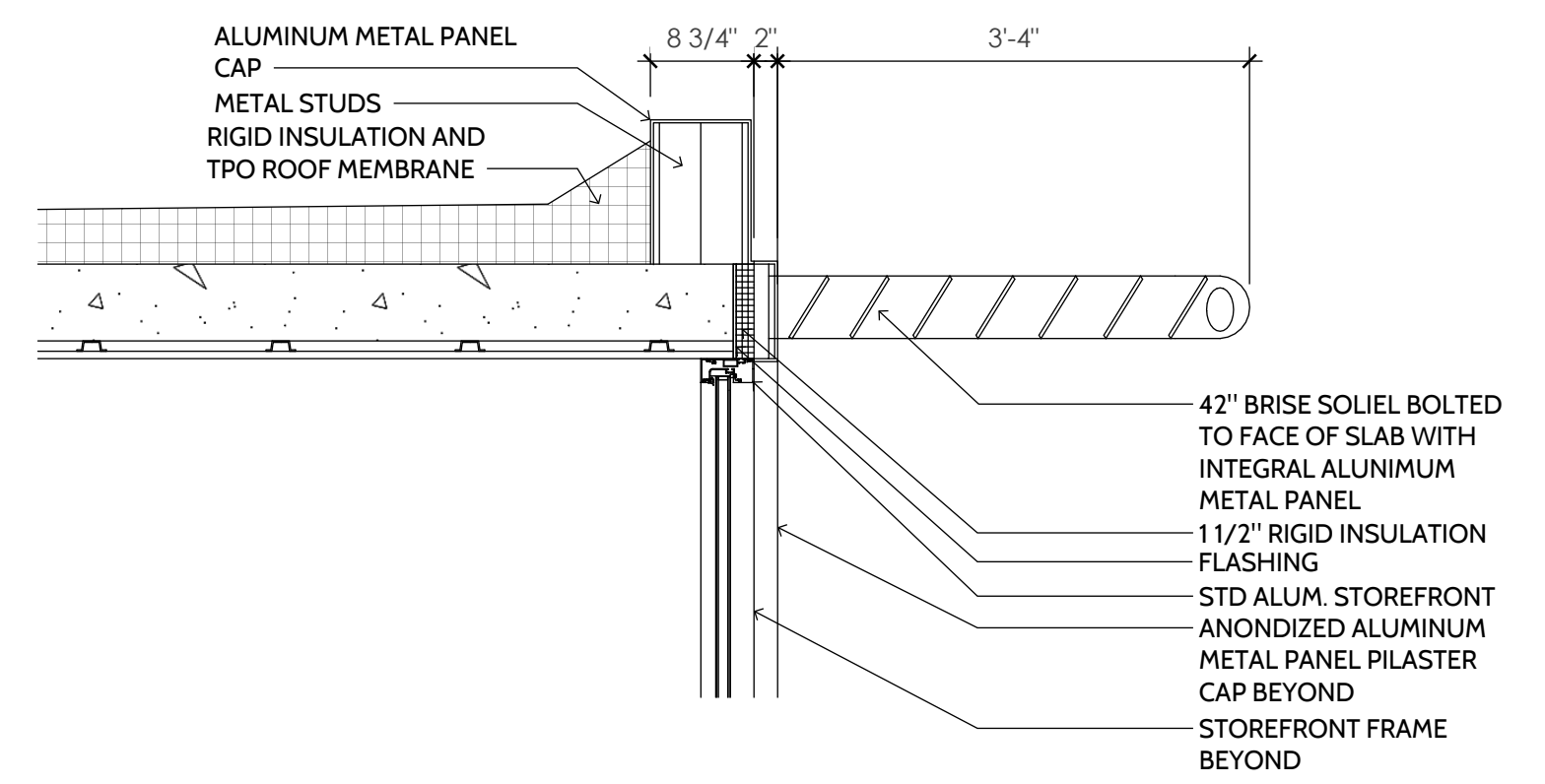

PARAPET WALL

3/4" = 1'
A2
3

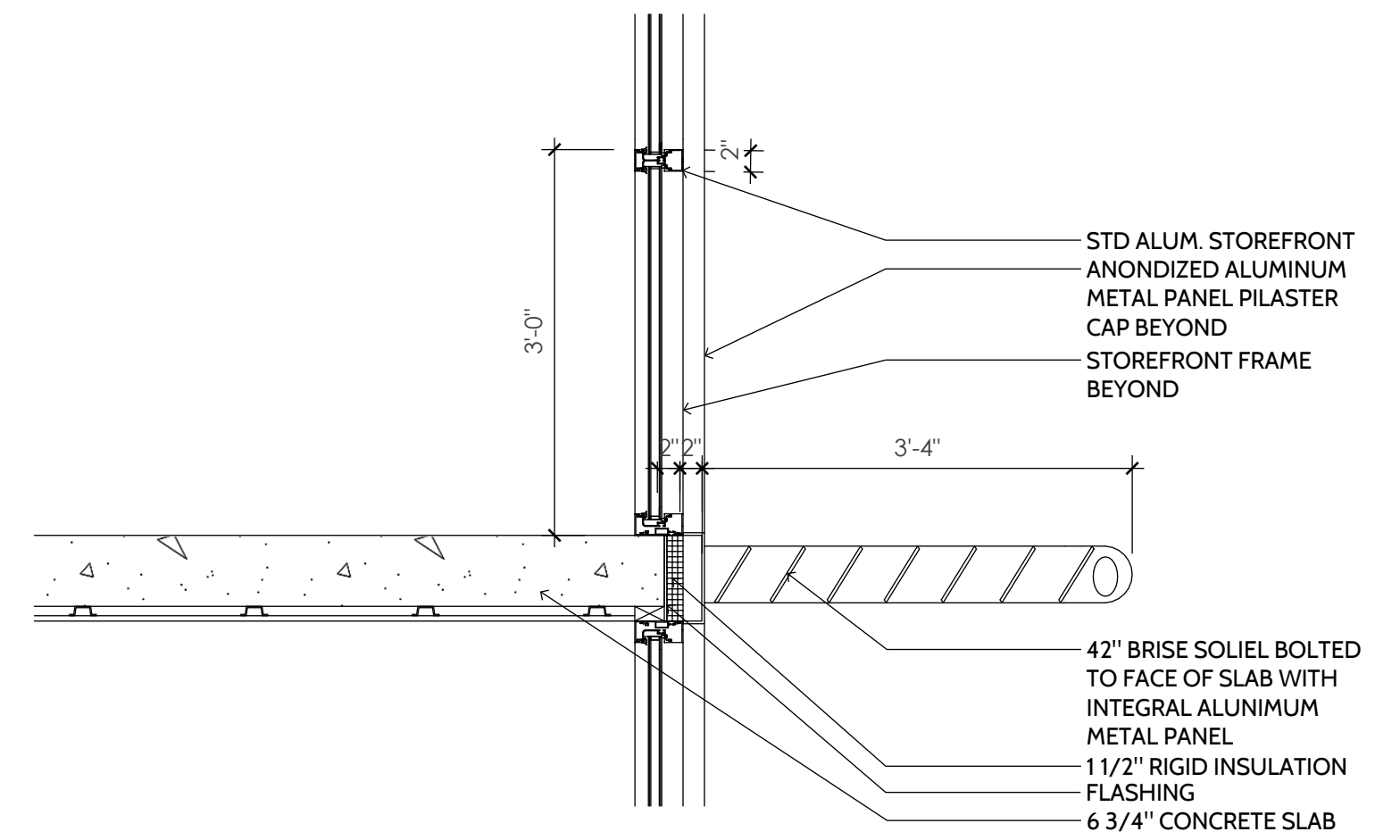

TYPICAL BRISE SOLEIL AT SLAB CONNECTION

3/4" = 1'
A2
4

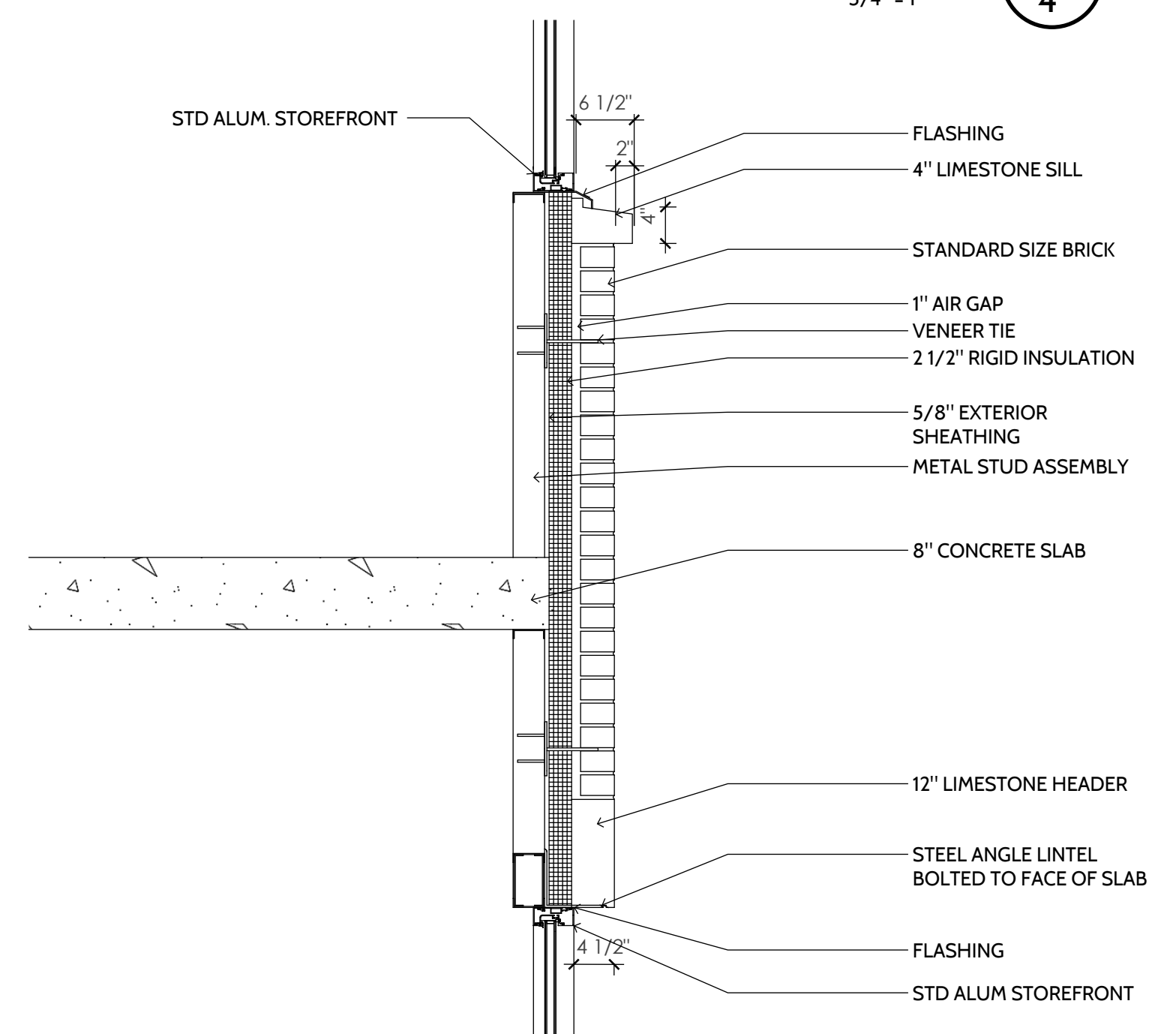

SILL AND HEADER AT 4TH FLOOR

3/4" = 1'
A2
5

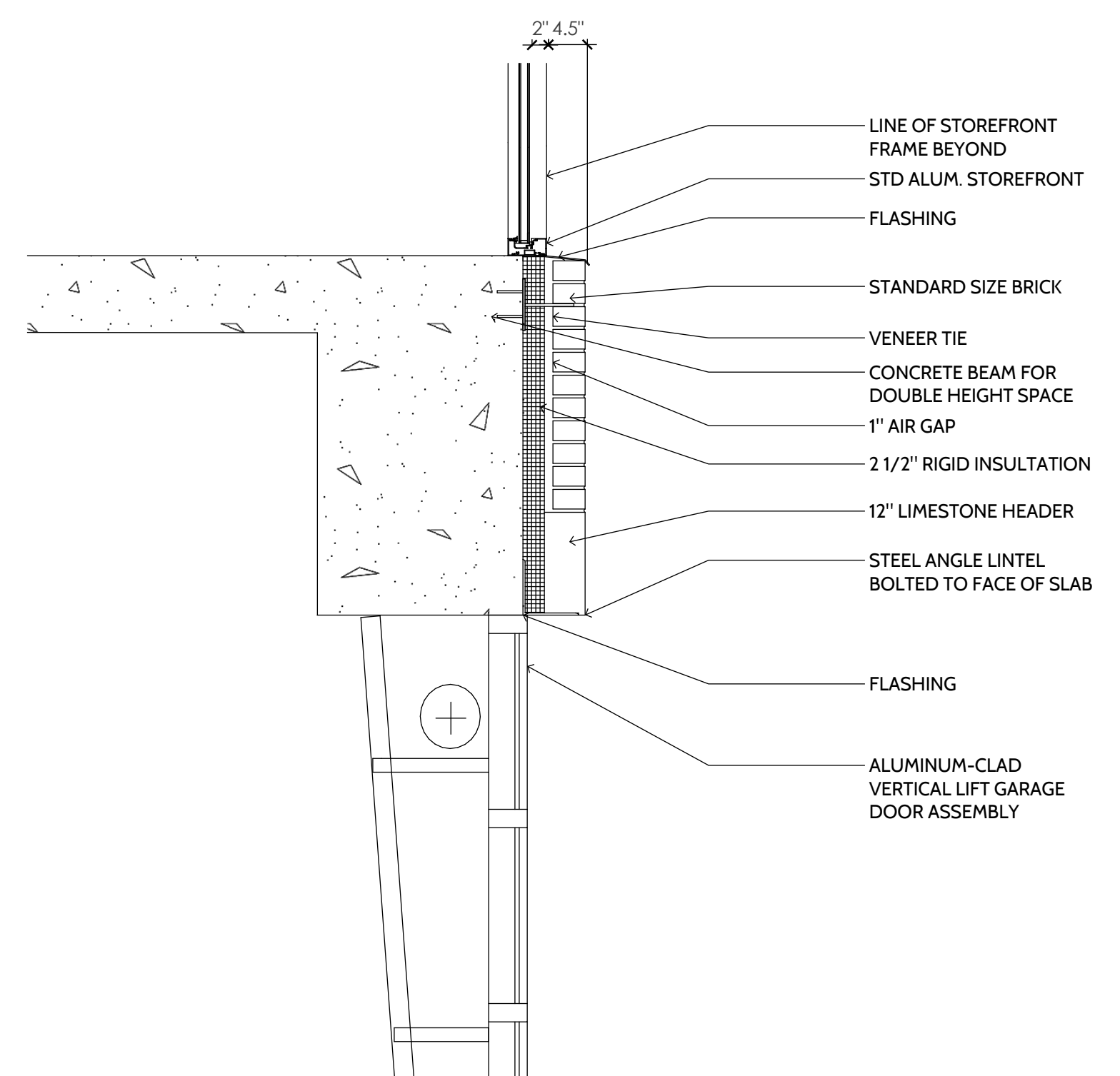

HEADER AT VERTICAL LIFT GARAGE DOOR

3/4" = 1'
A2
6

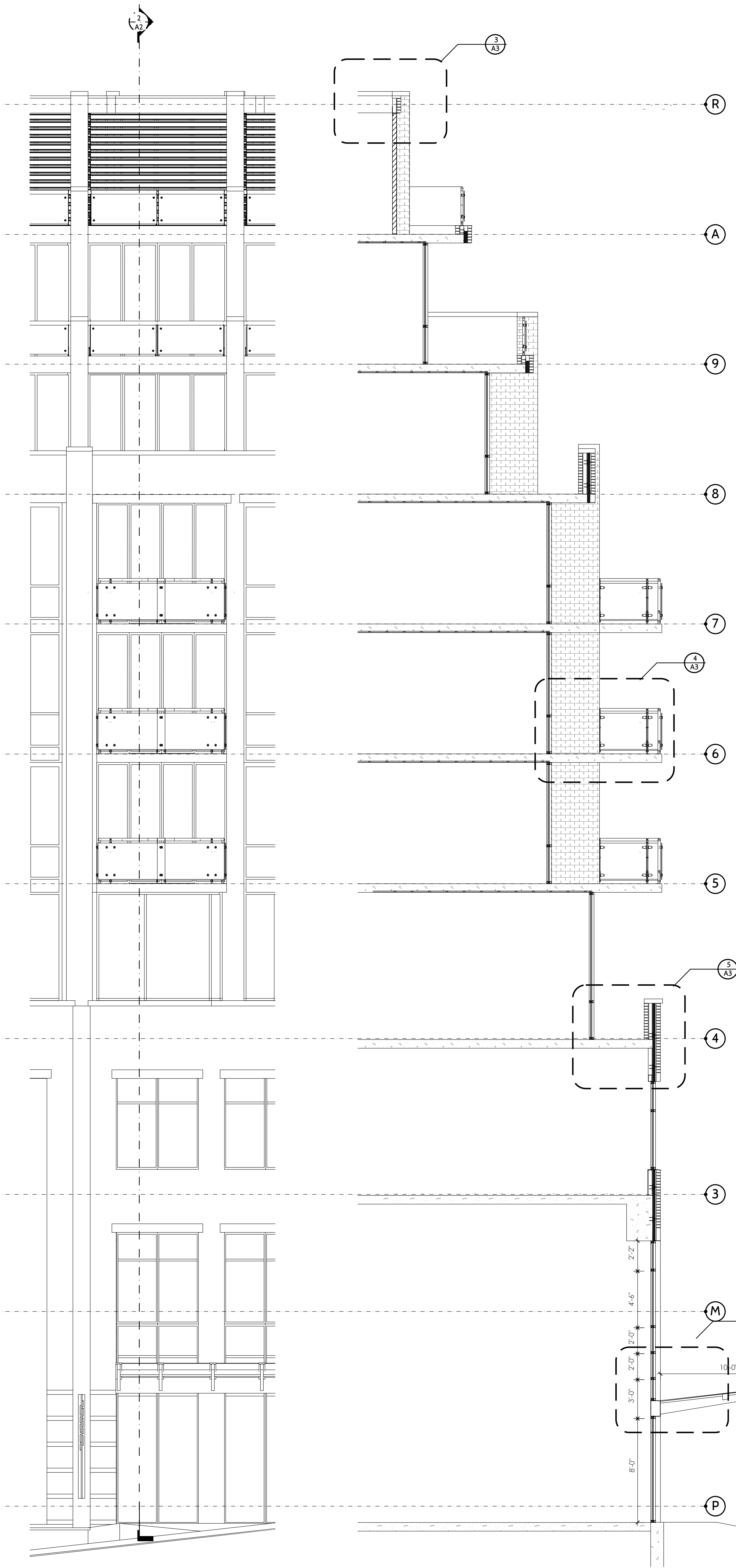

WATER STREET PARTIAL ELEVATION A3
1
1/4" = 1'

WATER STREET BALCONY SECTION A3
2
1/4" = 1'

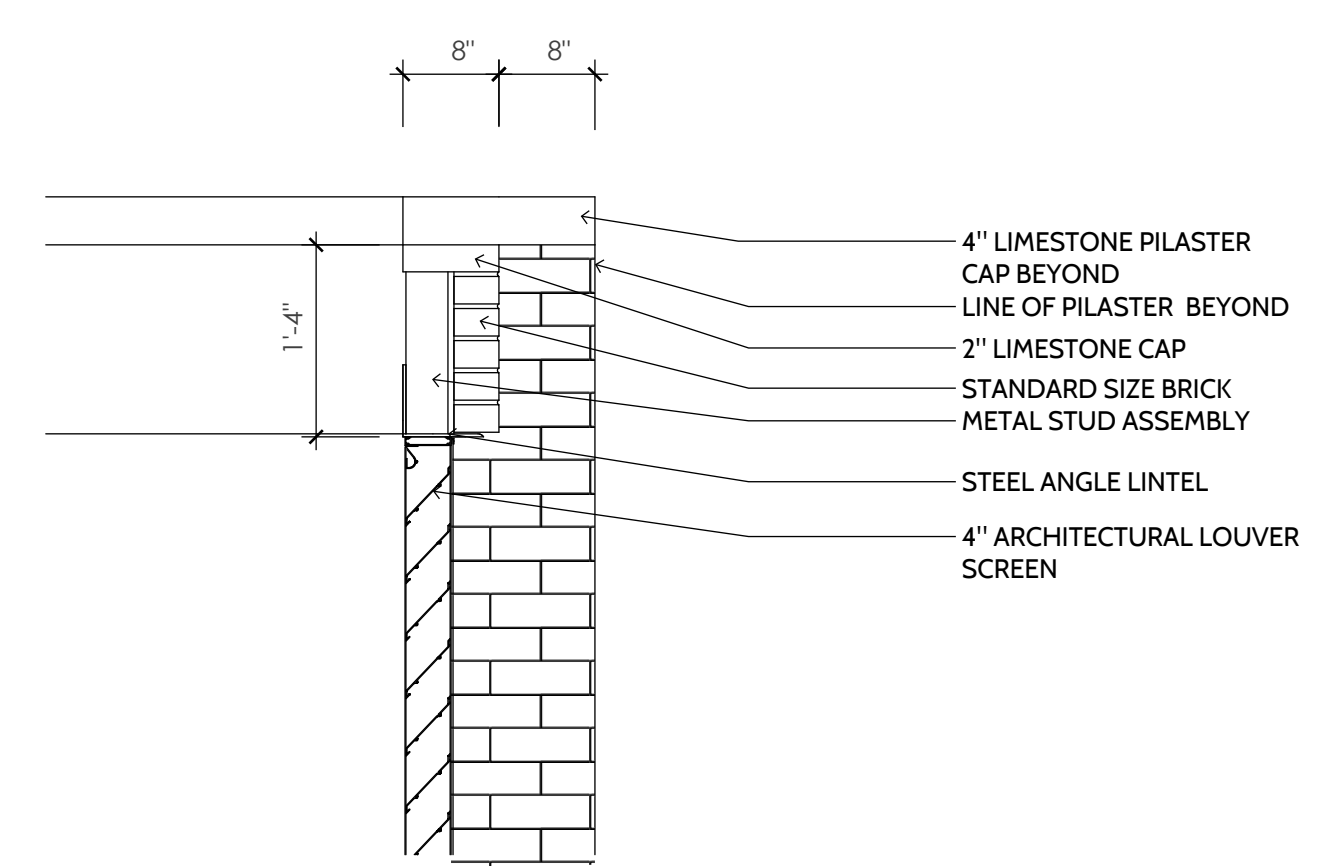

HVAC ENCLOSURE AT APPURTENANCE A3
3
3/4" = 1'

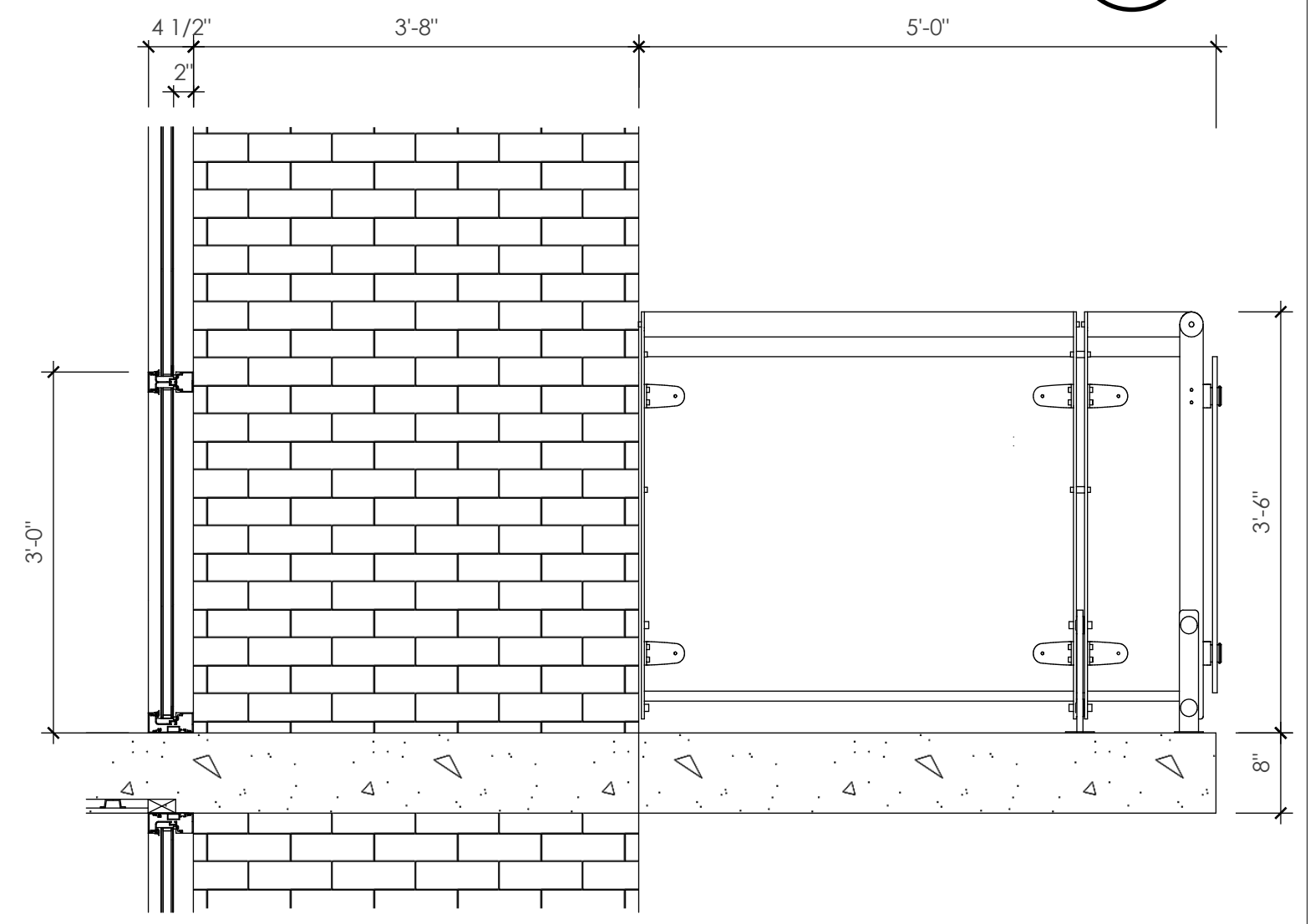

TYPICAL BALCONY OVERHANG CONDITION A3
4
3/4" = 1'

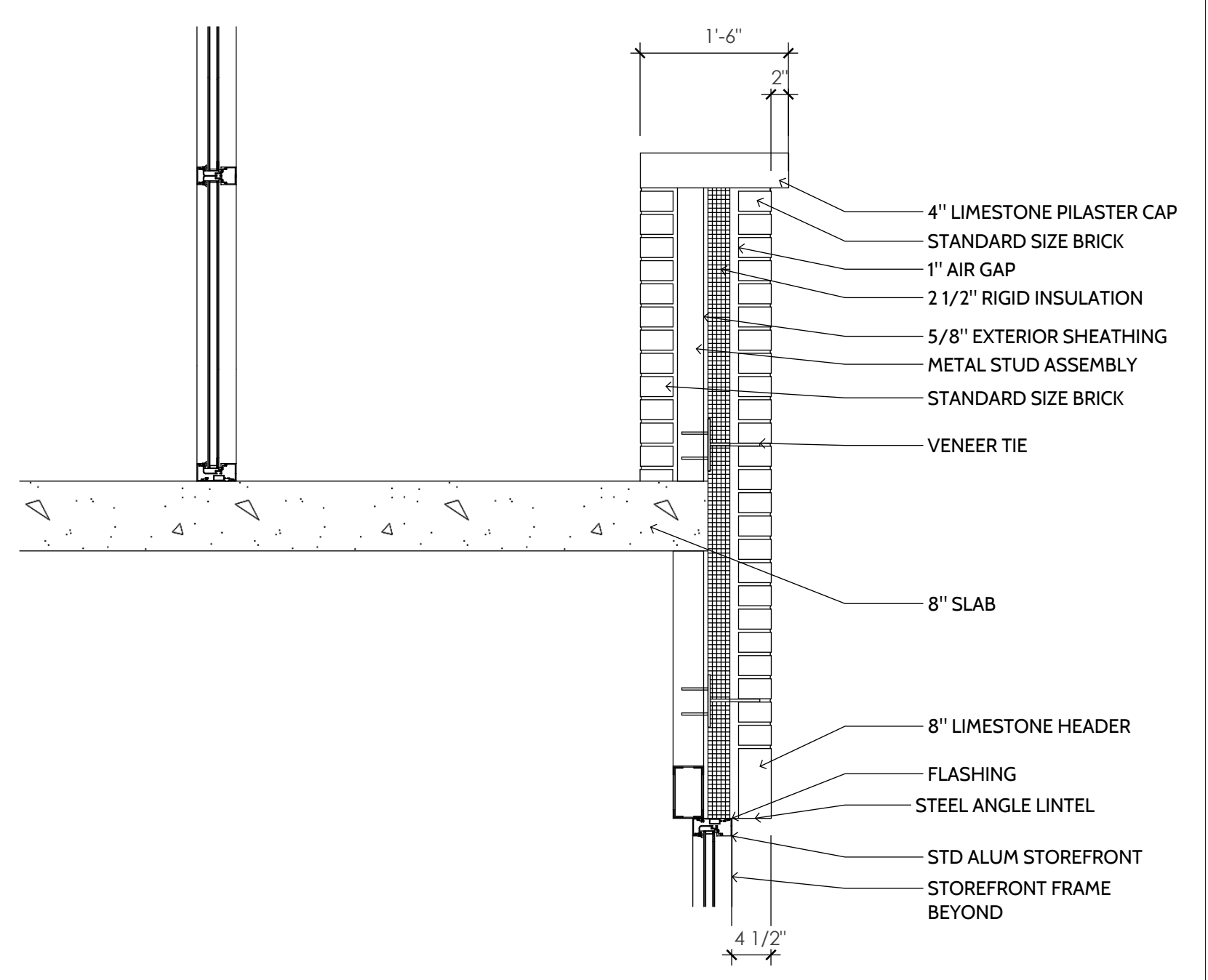

SILL AND HEADER AT 4TH FLOOR A3
5
3/4" = 1'

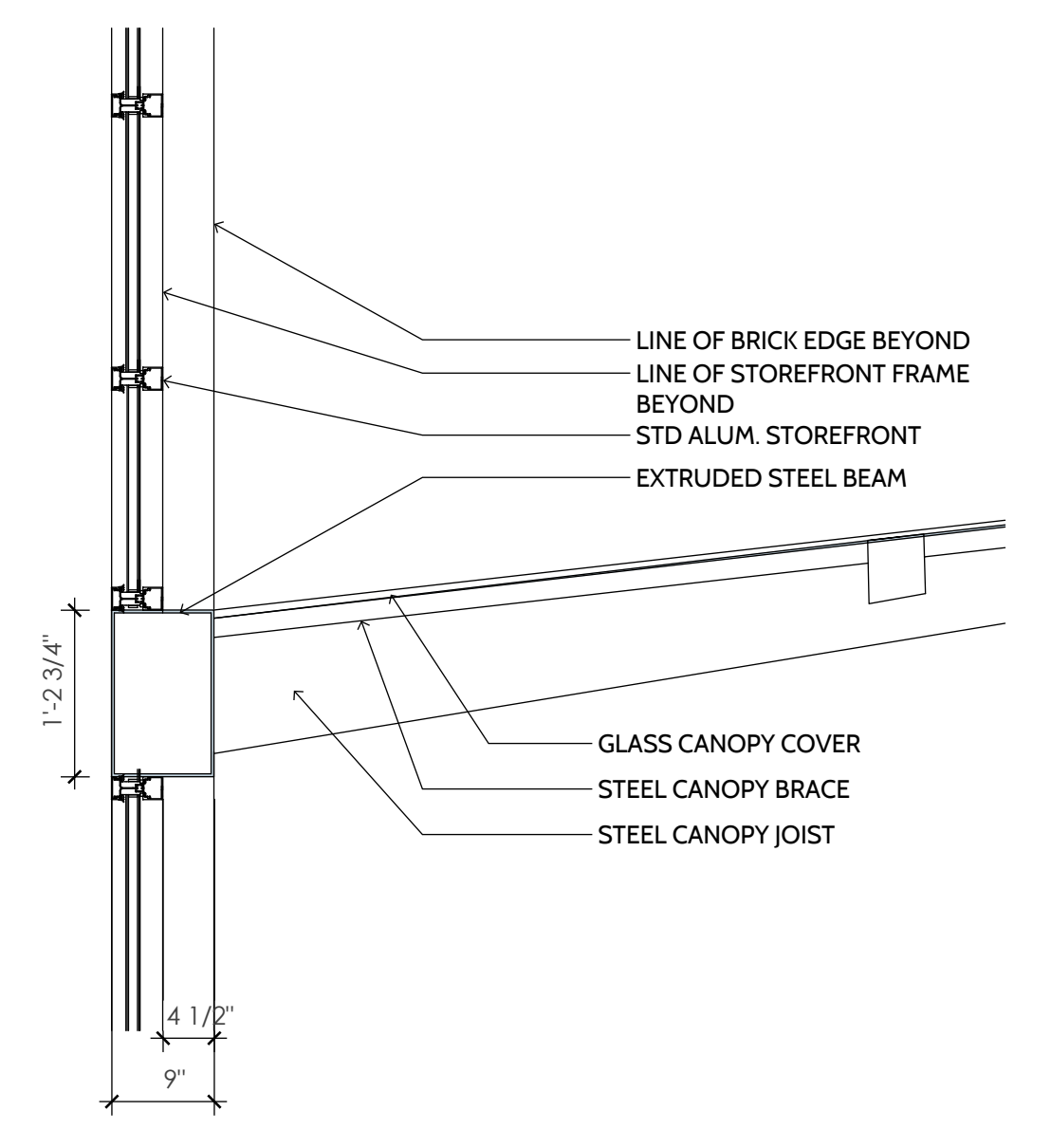

HEADER AT VERTICAL LIFT GARAGE DOOR A3
6
3/4" = 1'

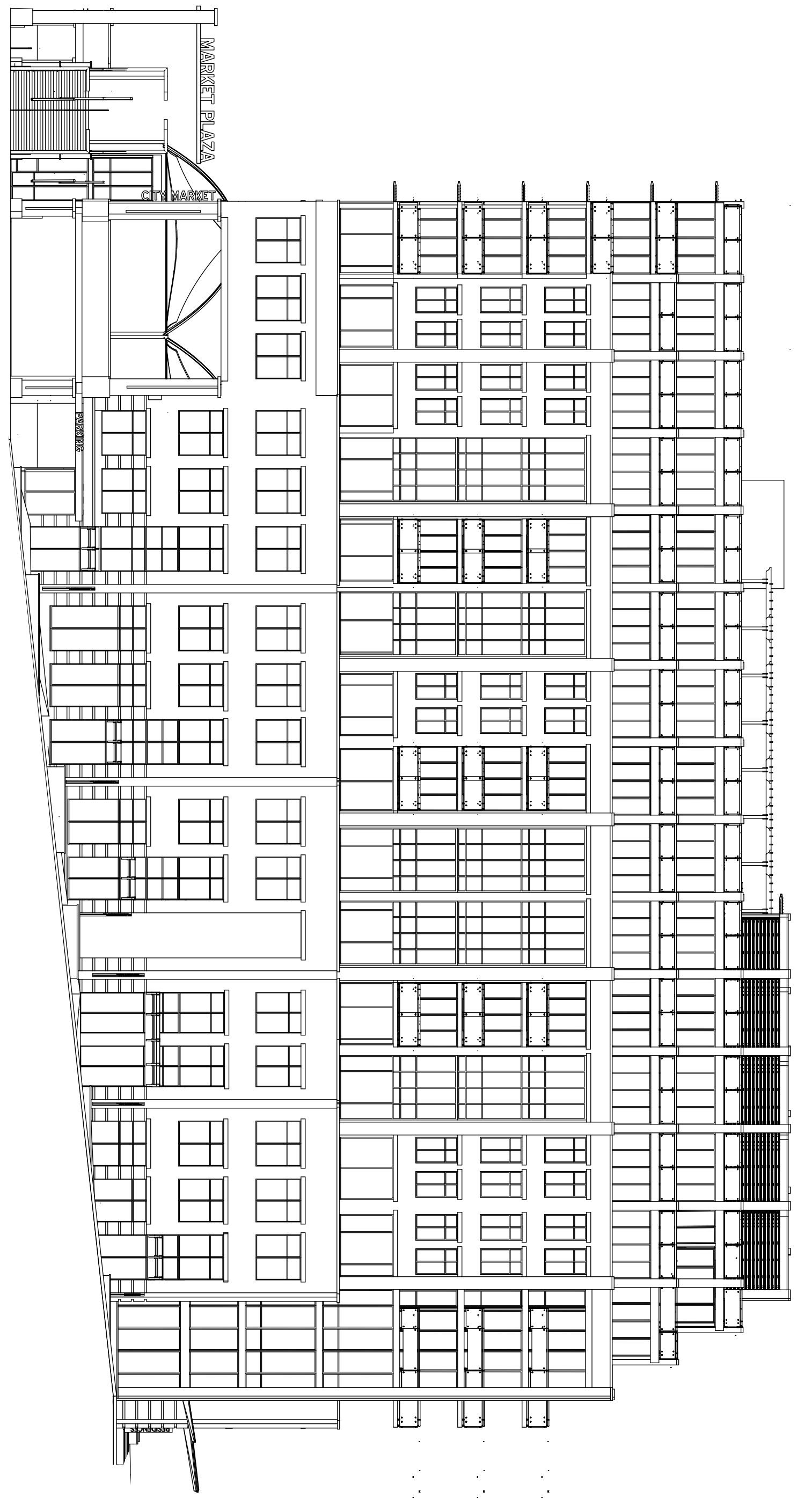

WATER STREET ELEVATION

1/8" = 1'

A4
1

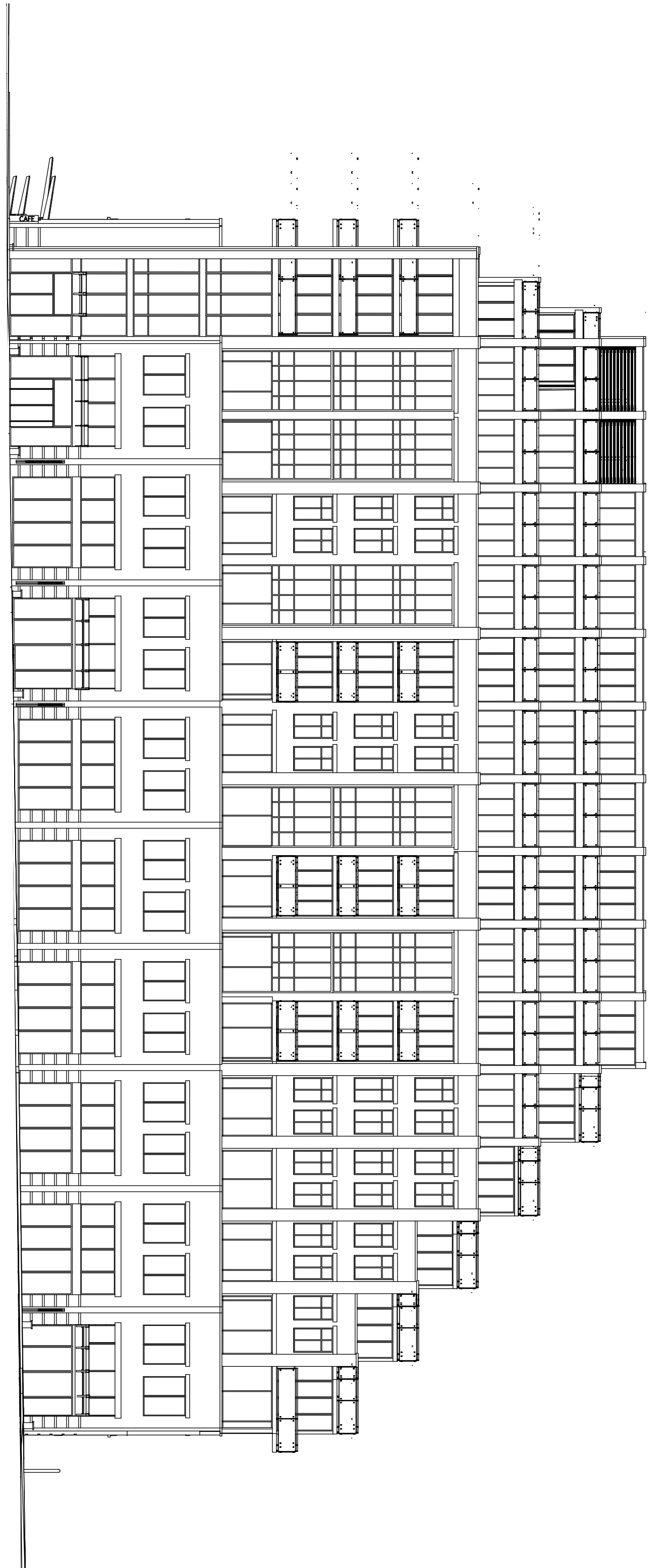

SECOND STREET ELEVATION

1/8" = 1'

A4
2

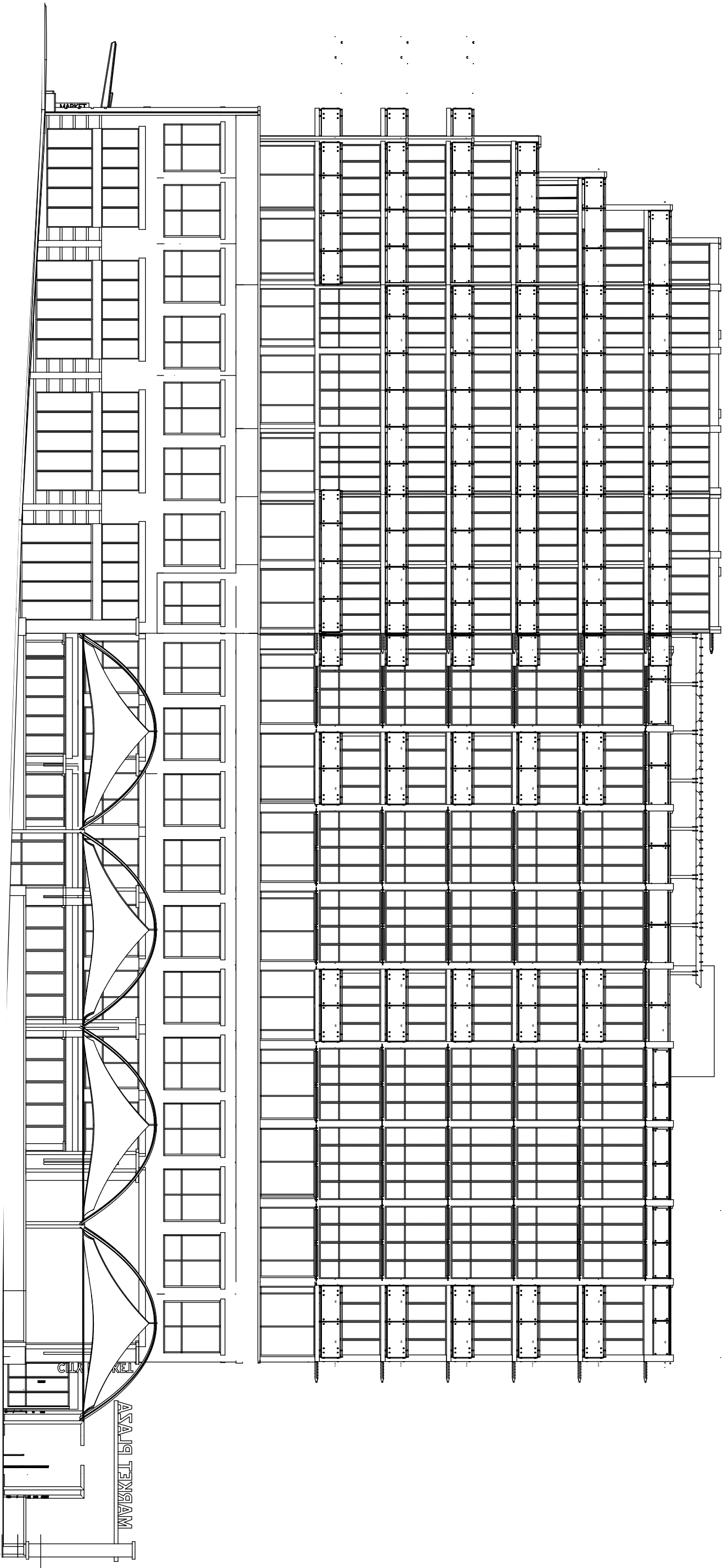

SOUTH STREET ELEVATION

1/8" = 1'

A4
3

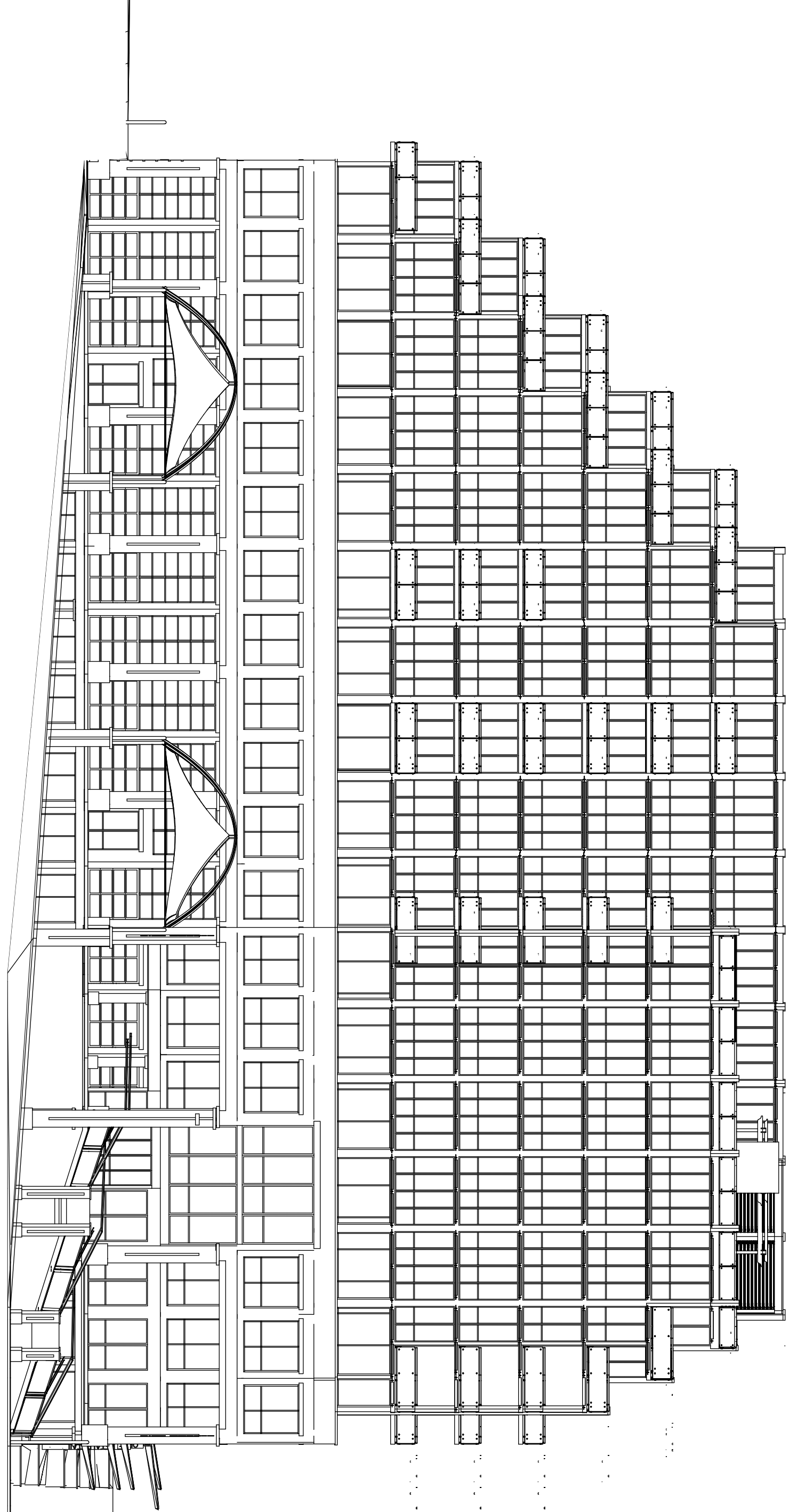

FIRST STREET ELEVATION

1/8" = 1'

A4
4